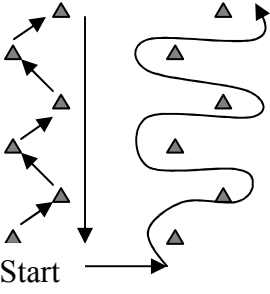
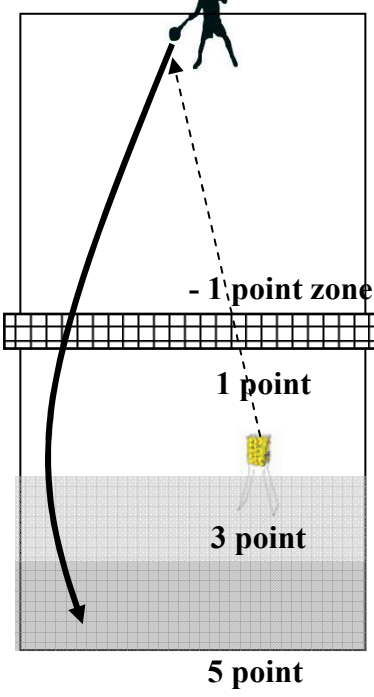

<p>WEEK 20</p>	
<p>Beginners</p>	<p>Depth</p>
<p>Aim</p>	<ul style="list-style-type: none"> To practice the skills necessary to hit the ball with depth, specifically, techniques to: <ol style="list-style-type: none"> hit the ball over the service line (or marked area) identify and move to return a deep ball or drop shot
<p>Warm Up</p> 	<p>Agility Circuit Combine side stepping, sprinting and weaving by setting up cones to create an agility course. From the Start Position:</p> <ul style="list-style-type: none"> the player must side-step from one cone to another. the player must then sprint line 2. then weave in and out of the cones to the finish line. <p>Coaching Notes: This is a good activity combining both speed and agility. As soon as player 1 gets to the sprint section, then player 2 can begin the side-stepping section. This gets several players completing the drill at one time and motivates them to catch up to the player in front of them.</p>
<p>Activities</p> 	<p>Basket Drill – Depth drill</p> <ul style="list-style-type: none"> Set up the court into zones as illustrated below, rewarding players for hitting the ball as deep into the court as possible. Shots into the net are penalised with - 1. The coach feeds an easy paced ball, 5 to each player. Demonstrate a swing with a long follow through aiming high over the net. Players can be split into two teams with scores being accumulated. A race to 50 points may add an element of excitement. Remember that you want the beginners to have so much fun they don't even realise they are learning something. <p>Coach Rally Set players up for a rally with all players back on the baseline. The coach manipulates his/her feeding between “DEEP” balls and “DROP SHOTS”. The beginners must learn to “read’ the depth of the shot that they are receiving and act accordingly, moving forwards or backwards. At first, begin the rally with the coach calling out the shot he/she intends to start with. This will give the player a head start. Progress to a rally between players with players starting the rally with a drop feed.</p>

--	--

Intermediate	Depth
Aim	Players getting used to drop shots and deep balls
Warm Up	High 5 Tennis Players rally in the mini court After each shot players “high 5” a team mate waiting on the side line Aim for longest rally then rotate.
Drills	Depth Drill Set up target areas as illustrated in the Beginners Lesson Plan. Add a degree of difficulty to the drill by making players move to the ball and maintain the depth of their shot. To create the movement have players recover to a “home base” after each shot.
Games	½ Court Tennis Start rally with an under arm serve. First to 5 points – automatic win if ball ends up beyond ¾ court. Rotate players.

½ Court Tennis

Mark out a depth area with lay down lines.

Rally normally but reward a ball hit beyond this line with an automatic point.

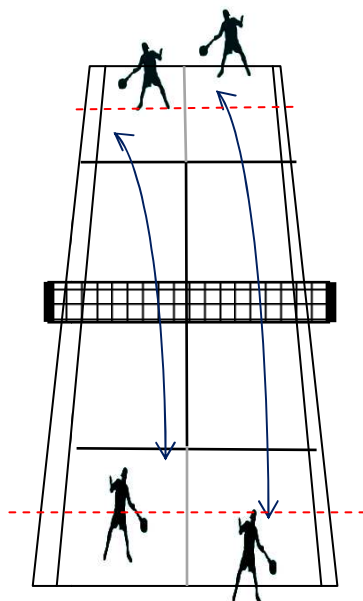

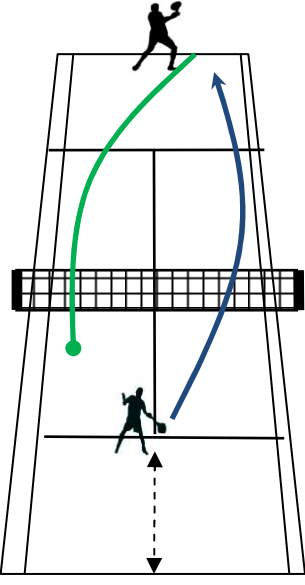
Squad	Depth
Aim	Explore using depth to control point play
Warm up	Mini / Full Tennis;
Technical	Using slow to fast swing pattern to create depth
Tactical	Manipulating depth at the appropriate tactical moment
Discussion	Introduce the 5 ball controls; Height, Spin, Speed, Direction, Depth <i>Coach: How can we safely pressure our opponent?</i> <i>Answer: Depth</i> <i>C: How to we create depth?</i> <i>A: Low to high & slow to fast swing pattern. [demonstrate swing]</i>
Drills	Basket Drill – Depth Game – aiming land the ball in last ¼ of court <i>... progress to</i> Rally Drill – Depth Game – 1 point for every shot over the service line. 1 st to 11. Coach feedback - <i>“more height to create depth; more topspin to keep the ball in”.</i>
Discussion	Using drop shots for variety C: What is a tactic to use against players; who are slow or play behind the baseline? A: Drop Shot. [demonstrate grip and swing change]
Drills	 <p>Basket Drill – Players alternate hitting deep then short, grooving the feel for manipulating depth ... <i>progress to</i> Rally Drill – Drop Shot Scramble</p> <ul style="list-style-type: none"> • Player A starts at the service line – they drop feed to Player B and then run back to the baseline. • Player B executes a drop shot – player A has to scramble forwards to cover the drop shot. • Play the point out. <p>Coach instruction; <i>“continental grip, cushion the shot, use spin to absorb the ball”</i></p> <p>Feed = _____</p> <p>Drop Shot = _____</p>
Point play	Use markers and create an area (approx. 2 racquet lengths) inside the baseline and out from the net; winning shots that land in this area [very deep or drop shot] are worth double points.